

# PAG ™

Professional Broadcast Equipment

## ***Pagbelt NMH***

Ni-MH Battery Belts



Instruction Manual



## Pagbelt NMH - General Arrangement:

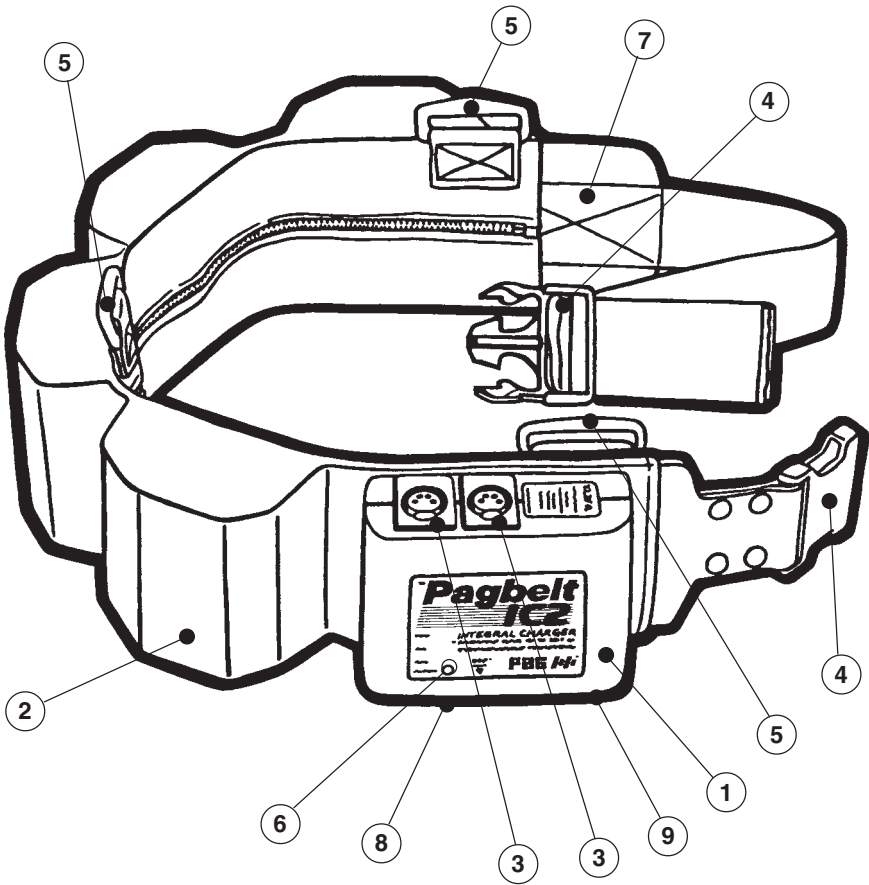

1. Integral charger/cut-out pocket.
2. Deep moulded one piece leather case.
3. Twin output sockets.
4. Quick release buckle.
5. Shoulder harness attaching rings.
6. Charging/mains LED.
7. Waist strap.
8. Over discharge and thermal protection reset button.
9. Mains input socket.



**Professional Broadcast Equipment**

# **Pagbelt NMH**

Nickel-Metal Hydride Battery Belts

## Instruction Manual

### **CONTENTS**

<b>SECTION</b>		<b>PAGE</b>
1	SPECIFICATION	2
2	CARE AND MAINTENANCE	4
3	INSTRUCTIONS FOR USE	6
4	SAFETY	8
5	WARRANTY	9

## SECTION 1

# SPECIFICATION

### 1.1 **Pagbelt NMH Range:**

Pagbelt NMH is a Nickel-Metal Hydride battery belt that incorporates an integral overnight charger, and is available in the following models:

<b>Model 9212</b>	<b>12.0V</b>	<b>10Ah</b>
<b>Model 9213</b>	<b>13.2V</b>	<b>10Ah</b>
<b>Model 9214</b>	<b>14.4V</b>	<b>10Ah</b>
<b>Model 9224</b>	<b>24.0V</b>	<b>10Ah*</b>
<b>Model 9230</b>	<b>30.0V</b>	<b>10Ah*</b>

*\*Supplied with shoulder harness.*

### 1.2 **Cells:**

Premium grade Nickel-Metal Hydride sealed rechargeable cylindrical cells.

### 1.3 **Voltage:**

Nominal voltage 1.2V per cell.

### 1.4 **Capacity:**

9Ah measured at the one-hour rate.

### 1.5 **Over Discharge Protection (ODP):**

Incorporates the PAG ODP circuit which will trip at the following voltages:

12.0V	8.5V - 9.5V
13.2V	9.5V - 10.5V
14.4V	10.5V - 11.5V
24.0V	17.0V - 19.0V
30.0V	22.0V - 24.0V

### 1.6 **Thermal Protection:**

The output sockets become isolated if cell temperature exceeds 70°C and can be reset when the temperature falls by pressing the ODP reset button.

### 1.7 **Short Circuit Protection:**

The battery belt is protected against short circuit and excessive currents by means of a self-resetting protection device. Rated maximum continuous current is 10 Amperes. The protection device will allow current surges up to 15 Amperes, but will trip if a continuous current in excess of 12 Amperes is drawn.

### **1.8 Output Connectors:**

Twin XLR-4 sockets wired in parallel as follows:

#### **Pin Connection**

- 1 Negative (-)
- 2 No connection
- 3 No connection
- 4 Positive (+)

### **1.9 Pagbelt Construction:**

Battery pouches are deep moulded from top-quality full chrome hide. The electronics circuits and the connectors are mounted in a housing which is injection moulded from glass reinforced nylon.

### **1.10 Waist Strap:**

Waist strap incorporates quick release buckle and is secured to the belt carcass.

### **1.11 Operating Temperature Range:**

0°C to +40°C.

### **1.12 Internal Charger Input Supply:**

100V to 250V AC. Frequency 50Hz to 60Hz.  
Maximum consumption 50W.

### **1.13 Input Connector:**

Conforms to CEE22 and IEC 65.

### **1.14 Charger Output Voltage:**

40V DC Maximum

### **1.15 Output Current:**

1000mA.

### **1.16 Charging Indicator:**

Indicator is lit when integral charger is operating.

### **1.17 Safety:**

Designed to comply with Electrical Safety Standard BS EN 60335 Part 2 Section 2.29 Class 2 (double insulated). Charger is designed for indoor use only. UK mains lead fitted with 1" fuse to BS 1362 rated 5A.

## SECTION 2

# CARE & MAINTENANCE

- 2.1 The battery belt can be stored indefinitely in any state of charge (even totally discharged) without significant loss of cell life.
- 2.2 Maintenance charging is not required.
- 2.3 Store in a cool dry place. Ideally the temperature should be from -20°C to +30°C. High storage temperatures (above +45°C) reduces the battery's life because of unwanted chemical reactions. Excessively low storage temperatures (below -30°C) should also be avoided since the electrolyte may freeze, resulting in permanent cell damage.
- 2.4 After prolonged storage do not fast-charge the battery immediately. The cells should first be reformed and balanced by giving the battery a slow (C/10) charge for 24 hours. When the battery is subsequently put into service, 2 or 3 cycles of charge and discharge may be needed to return the battery fully to its rated capacity.
- 2.5 The battery belt should be in a fully charged state before use. Even after one week in storage the battery should be given a top up charge before use.

At room temperature (20°C) Nickel-Metal Hydride batteries lose 1% of their charge per day. The top-up charge needed is one hour at C/10 for each week of storage.

- 2.6 Charge the battery belt only from constant current chargers - see Section 3, Instructions for Use. Constant voltage chargers must not be used.
- 2.7 For maximum output, use within the temperature range 0°C to +40°C. Never operate outside of the temperature range -20°C to +45°C.
- 2.8 Do not immerse the battery belt in water. Should this happen, drain all excess water and return the belt to your nearest PAG dealer as soon as possible for service.
- 2.9 Do not connect to the supply while disassembled. Qualified electronics engineers who wish to gain access to internal assemblies should note that parts of the power circuit retain high voltage even after the mains supply has been disconnected. Wait for a period of five minutes following disconnection before disassembly.

- 2.10 The battery output is protected by means of a self-resetting over-current device. If the output is overloaded, the device will trip, causing the output to become open circuit. In this event, disconnect any equipment from the output, and only reconnect it **WHEN THE CAUSE OF OVERLOAD HAS BEEN ESTABLISHED**. This could be caused by a fault with the cables, the equipment powered by the battery belt, the connectors, or a fault internal to the battery belt.
- 2.11 The leather is wax treated during manufacture to resist water absorption in normal use. Occasional cleaning and polishing with colourless wax polish will maintain the suppleness of the leather, water resistance and appearance.
- 2.12 Cells must never be replaced indiscriminately. All cells used by PAG Limited are carefully graded and matched because battery performance is only as good as the worst cell, and fitting unmatched cells will quickly result in battery failure.
- 2.13 PAG Limited maintains a comprehensive Service Department for the repair and service of all PAG batteries and charging equipment. The department is based at the London factory and is therefore able to call upon full manufacturing and test facilities. Should your Pagbelt require servicing we recommend that you contact your PAG Dealer or the PAG Service Department to maintain the quality standard for which you originally chose a PAG product.

## SECTION 3

# INSTRUCTIONS FOR USE

### 3.1 OPERATION OF THE ODP CIRCUIT

Nickel-Metal Hydride batteries should not be discharged too deeply. If the voltage of a battery pack falls below 75% of its nominal voltage (e.g. 9V for a 12V battery) cells may be damaged by voltage reversal, thus shortening the life of the battery.

To guard against this, the belt is provided with an Over-Discharge Protection circuit which will cut power to the output connectors when the belt has reached its maximum discharge state. See Section 2.5 for the ODP trip voltage.

Additional to the above, the output sockets will also become isolated if the cell temperature exceeds 70°C.

A single button is provided to reset these circuits and it is marked ODP reset.

If a battery belt is to be charged via an external charger the ODP circuit should be reset if it has been tripped.

If the ODP circuit has tripped due to overheating of the cells, the belt must be allowed ample time to cool (at least 1 hour) and the cause of the heating established before the ODP circuit is reset.

The Pagbelt incorporates an internal overnight charger. This charger operates independently of the ODP circuit.

### 3.2 CHARGING INSTRUCTIONS - GENERAL

The Pagbelt NMH must be charged only from constant current chargers. Constant voltage chargers (as used for example for charging lead acid batteries) are not suitable for use with nickel-metal hydride batteries, and may damage them irreparably.

When the belt has been discharged at high current rates it will become warm, and it is advisable to let it cool before recharging it. The recommended charging temperature range is 0°C to +40°C.

The belt incorporates an internal overnight charger, see Section 3.3 below for operating instructions.

The belt may be fast-charged using the appropriate PAG microcomputer-controlled fast charger. See Section 3.4 below for instructions.



### **3.3 CHARGING FROM THE INTERNAL CHARGER**

Warning: if moisture has entered the charger housing (such as may occur if it has been immersed in water) do not connect it to the mains supply, but return the Pagbelt to your nearest PAG Dealer for service. Ensure that no equipment is connected to the output connectors during the charging process.

The charger housing will become warm in use. To allow adequate cooling, do not place objects on or around the belt while it is being charged.

Connect the integral charger to the supply using the supply cord provided. The charging indicator will light.

The integral charger will correctly charge the battery belt in 12-14 hours to full capacity from a fully discharged state.

No damage or gain will result if the belt is left on charge using the integral charger for an extended period beyond which the battery has become fully charged.

### **3.4. FAST CHARGING**

PAG Limited offer a range of sophisticated microcomputer-controlled fast-chargers which will safely charge the Pagbelt NMH and extend its working life.

Not all fast-chargers provide the close monitoring of the PAG ACS fast-charge process which is essential to ensure safety and to maintain the life of the battery. The PAG range of fast-chargers incorporate PAG ACS, a unique microcomputer-control that enables these chargers to fast-charge safely any reputable make of battery pack.

**READ CHARGER HANDBOOK BEFORE USE.**

Ensure that no equipment is connected to the output connectors during the charging process, and ensure that the ODP cut-out is reset by pressing the reset button.

Connect the charging lead from the charger to an output connector (XLR-4) on the Pagbelt using an adaptor lead if necessary. PAG microcomputer-controlled fast-chargers will automatically terminate the charging process when the battery is fully charged. For typical charging times and full operating instructions refer to the charger handbook.

**IMPORTANT:** Do not connect the integral charger to the supply while the battery is being charged by means of an external charger.

## SECTION 4

# SAFETY

- 4.1 When used correctly, rechargeable Nickel-Metal Hydride batteries are a rugged, safe, clean and trouble-free method of storing power. The cells offer high energy densities and do not deteriorate when left in a discharged state, making them ideally suited to applications where reliable portable power is required. However, the user should be aware that incorrect use could present a hazard. In the interests of safety and the protection of our environment, please read and observe the following health and safety information.
- 4.2 **GENERAL:**  
Do not put in fire or mutilate, cells may burst or release toxic material. Do not short circuit cells as this may cause burns.
- 4.3 **CORROSIVE ELECTROLYTE:**  
The electrolyte is a mixture of potassium hydroxide (KOH) and water. This can cause chemical burns to human tissue. Should leakage occur, wear protective gloves when handling all contaminated materials. In the event of contact with the skin, flood copiously with clean water. If significant amounts of KOH are involved, or if any has touched the eyes, seek medical attention.
- 4.4 **ACCIDENTAL SHORT CIRCUITING:**  
Nickel-Metal Hydride cells can deliver power at very high rates. PAG battery belts are protected at the output connectors by a self-resetting over-current device, but severe mechanical abuse of a belt could result in damage to cells, and short circuit internal to the battery. Arcing, excessive heat and the liberation of combustible gas could result, with the potential for personal injury or ignition of adjacent flammable materials.
- 4.5 **DISPOSAL:**  
Do not mutilate batteries - corrosive electrolyte will be released (see 4.3 above).  
Do not incinerate - danger of explosion and release of toxic fumes.  
Do not dispose of batteries or cells in a charged condition (see 4.4 above).  
Expired batteries must be disposed of in accordance with the appropriate regulations or legislation.

PAG Ltd. offers a recycling service for expired PAG batteries. These will then be properly and completely recycled. The potentially hazardous materials will be recovered and used again in the production of rechargeable cells.

Return batteries by prior arrangement to:  
PAG Ltd. 565 Kingston Road, Raynes Park, London SW20 8SA.  
Batteries must be in a discharged state and be clearly marked:  
"FOR RECYCLING".

## SECTION 5

# WARRANTY

- 5.1 Notwithstanding any provision of any agreement the following warranty is exclusive: PAG Limited warrants each Pagbelt it manufactures to be free of defects in material and workmanship under use and service for 18 MONTHS (2 years for the integral charger) from the date of purchase. This warranty extends only to the original purchaser. This warranty shall not apply to fuses or any product or parts which have been subject to misuse, neglect, accident or abnormal conditions of operation.
- 5.2 In the event of failure of a product covered by this warranty, PAG Limited will repair and calibrate equipment returned to an authorised service facility within the period of the warranty, provided the warrantor's examination discloses to its satisfaction the product was defective. The warrantor may, at its option, replace the product in lieu of repair. With regard to any equipment returned within this period, said repairs or replacements will be made without charge.
- If the failure has been caused by misuse, neglect, accident or abnormal conditions of operation, repairs will be billed at a nominal cost. In such a case, an estimate will be submitted before work is started, if requested.
- 5.3 The foregoing warranty is in lieu of all other warranties, express or implied, including but not limited to any implied warranty or merchantability, fitness or adequacy for any particular purpose or use. PAG Limited shall not be liable for any special, incidental, or consequential damages, whether in contract, tort, or otherwise.

PAG Ltd.  
565 Kingston Road  
Raynes Park  
London SW20 8SA

T +44 (0) 20 8543 3131  
F +44 (0) 20 8540 4116  
E sales@paguk.com  
www.paguk.com



## EU DECLARATION OF CONFORMITY

We **PAG Ltd.**  
**London, England.**

hereby declare that the products described below conform to the relevant requirements of the appropriate EU Directives. This declaration shall cease to be valid if modifications are made to the products without our approval.

PRODUCT: Pagbelt NMH Nickel-Metal Hydride battery belts.

MODEL: 9368, 9212, 9213, 9214, 9224 & 9230.

APPLICABLE EU DIRECTIVES: EMC DIRECTIVE 89/336/EU  
LOW-VOLTAGE DIRECTIVE 73/23/EU  
CE MARKING DIRECTIVE 93/68/EU

HARMONISED STANDARDS APPLIED: GENERIC:  
EN 50081 - 1 (EMISSIONS)  
EN 50082 - 1 (IMMUNITY)

PRODUCT SPECIFIC: EN 55022 - B EN 60555 - 2/3  
IEC 801 - 2/3/4 EN 60335 - 1  
EN 60335 - 2 - 29

Signed for and on behalf of PAG Ltd.

Alan Lavender  
Chief Executive.

Date: 1.7.09.